

A comparative study of electrochemical reactor configurations for the decomposition of copper cyanide effluent

M. L. LIN, Y. Y. WANG, C. C. WAN

Department of Chemical Engineering, Tsing-hua University, Hsin-chu, Taiwan

Received 25 November 1991; revised 20 March 1992

An electrochemical reactor packed with stainless steel fibres was used to oxidize a complexed copper cyanide solution. The reactor reduced the cyanide content from over 2000 p.p.m. to less than 100 p.p.m. in 4 h. The energy consumption (kWh (kg CN⁻)⁻¹) for a bipolar setup was larger than for the parallel setup. An analog circuit analysis qualitatively agrees with the experimental results.

1. Introduction

The packed-bed electrochemical reactor has been widely studied as a possible device for the oxidation of highly toxic cyanide effluent [1-3]. Although the basic anodic reaction of cyanide destruction is recognized to be



the detailed reaction mechanism is very complex. The copper complex can be in various forms, e.g. Cu(CN)₂⁻, Cu(CN)₃²⁻, Cu(CN)₄³⁻, and Tamura *et al.* [4] proposed that cyanide ions are oxidized at the anode by first forming cyanide radicals as follows,

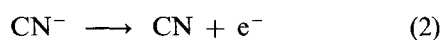

The detailed reaction mechanism was found to depend on the alkalinity [2]. Packed-bed reactors can be designed in two configurations. The first is the bipolar type [5], in which only the top layer and bottom layer are connected to the current collector. The intermediate layers are separated by porous insulators and function as bipolar electrodes. Numerous patents and applications have appeared in the past twenty years [6]. El-Ghaoui [1] found that in a bipolar reactor, high flow rate could cause bypass phenomena and reduce the current efficiency. Hwang [7] also derived a reactor design equation for the bipolar reactor. Another possible setup, in which all the electrodes are directly connected to either the outside positive or negative terminal in parallel, has also been found promising by Ho *et al.* [3]. They found that the effectiveness of a packed-bed electrode was limited to a layer no thicker than 1.9 cm. Although both the bipolar electrode and parallel setup have been studied individually, which system is superior under a given condition is still unknown and is of industrial interest.

Therefore an attempt has been made to carry out a comparative study on these two systems based on energy consumption and decomposition efficiency.

2. Experimental details

A schematic diagram of the reactor is shown in Fig. 1. Each layer of the electrode was 2 cm thick and was packed with stainless steel fibre. The geometric area of the fibre, which was 0.045 cm diameter, was estimated to be 53 cm² g⁻¹ by calculation. The electrode layers were separated by perforated circular plates of lucite 12 cm in diameter. The steel fibre and the current collector were made of 316 stainless steel and no noticeable corrosion was observed throughout the experiment.

For the bipolar reactor, only the top and bottom layers were connected to the negative and positive through a current collector. The intermediate layers become anodic on one side and cathodic on the other side.

A metering pump set the flow rate at 1.2 dm³ min⁻¹. The reactor bottom was packed with glass beads to reduce the entrance effect. The volume of solution prepared for one experiment was 7 dm³ and the initial cyanide to copper molar ratio *R* (CN/Cu) was set at 4.1:1 and the initial cyanide content at 2100 ± 50 mg dm⁻³. The pH of the solution was between 13 and 12 during the electrolysis.

Cyanide analysis during electrolysis was made by standard titration with AgNO₃ [8]. The copper content was measured by atomic absorption spectroscopy.

3. Results and discussion

3.1. Bipolar electrode reactor

Figure 2 shows the extent of cyanide decomposition with electrolysis time for various applied currents. It is clear that an increase in the current tends to speed the decomposition, as expected. However, the change in the decomposition rate does not exactly match the current increase, which implies the current efficiency is another important variable. The current efficiency is the fraction of anodic current actually being consumed in the decomposition reaction. Figure 3 shows that the anodic current efficiency, in general, decreases

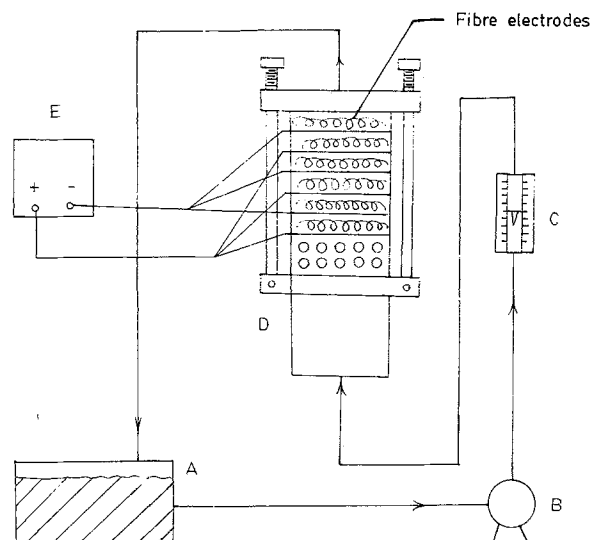

Fig. 1. Schematic diagram of the electrochemical reactor in a parallel setup: (A) electrolyte reservoir, (B) pump, (C) rotameter, (D) reactor, (E) power supply.

with time. Hence a compromise must be reached in process design based on the decomposition rate and energy consumption. The number of electrode layers in a reactor is also an important design factor. Figure 4 shows clearly that an increase of the number of layers is beneficial to the cyanide destruction. This is to be expected since additional layers result in additional electrode surface and a longer reaction residence time. For a given total current, additional electrode surface is equivalent to a smaller average current density, which should theoretically lead to an increase in current efficiency. This has also been shown in Fig. 5. An interesting phenomenon in Fig. 5 is that some of the current efficiency data apparently exceed 100%. This implies that the cyanide compounds are decomposed not only via electrochemical reaction but also via chemical oxidation.

3.2. Parallel electrode reactor

For the parallel electrode reactor, the electrolysis results are shown in Figs 6–9. The trend in this system is similar to that in the bipolar reactor. The decomposition rate increases as the current is increased (Fig.

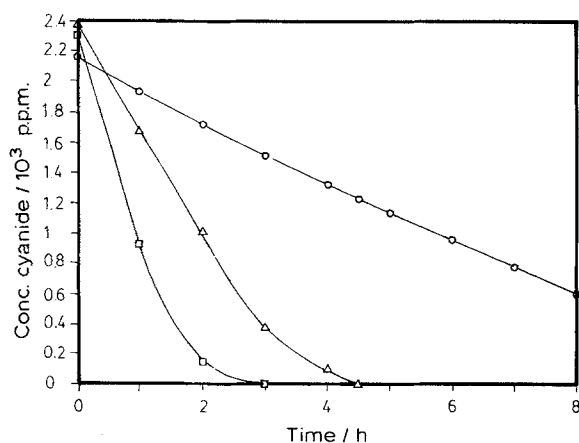

Fig. 2. Decomposition of cyanide with respect to electrolysis time in a 4-layer bipolar reactor. Current, I/A : (\square) 10, (Δ) 6 and (\circ) 2.

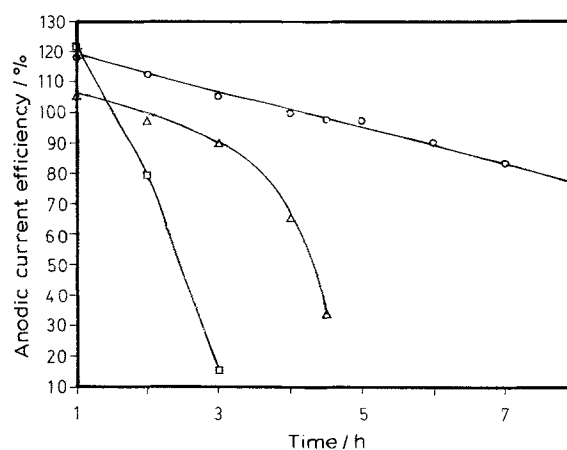

Fig. 3. Anodic current efficiency against electrolysis time in a 4-layer bipolar reactor. Current, I/A : (\square) 10, (Δ) 6 and (\circ) 2.

6), although the current efficiency falls (Fig. 7). A comparison between Figs 4 and 8 shows that both systems accelerate the decomposition if the number of electrode layers is increased. However, from Fig. 8, it is seen that an increase in the number of electrode layers from 4 to 6 has only a marginal effect.

3. Performance comparison

Table 1 shows the cyanide conversion percentage and energy consumption for the two systems after electrolysis for 3 h. It is obvious that for constant applied current of 8 A, the conversion for the bipolar system is higher than that for the parallel system. This is because the current efficiency of the bipolar system is slightly higher than that for the parallel system. For instance, in Fig. 5, after 3 h electrolysis, the current efficiency of a 4-layer bipolar system is about 88% while in Fig. 9, the current efficiency is only about 80% for a 4-layer parallel system. However, the energy consumption for a bipolar system is much higher than for a parallel system. This is because, for the same total current, the current density for a parallel system is, by definition, much smaller than that for a bipolar system connected in series. So the electrode polarization effect in a bipolar reactor is naturally more pronounced. In actual experiments, it was also

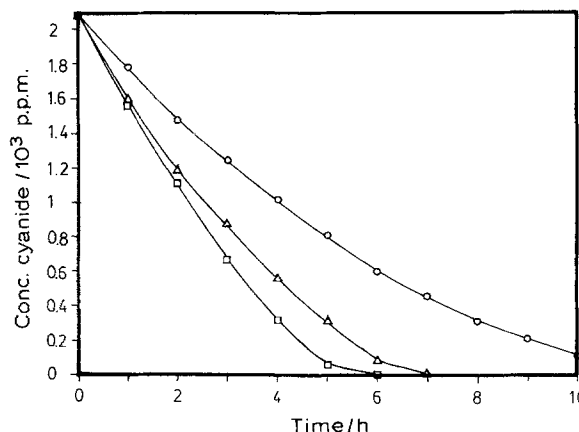

Fig. 4. Decomposition of cyanide in bipolar reactors with different electrode layers. Flow rate $2.0 \text{ dm}^3 \text{ min}^{-1}$, current 4 A. Layer: (\square) 6, (Δ) 4 and (\circ) 2.

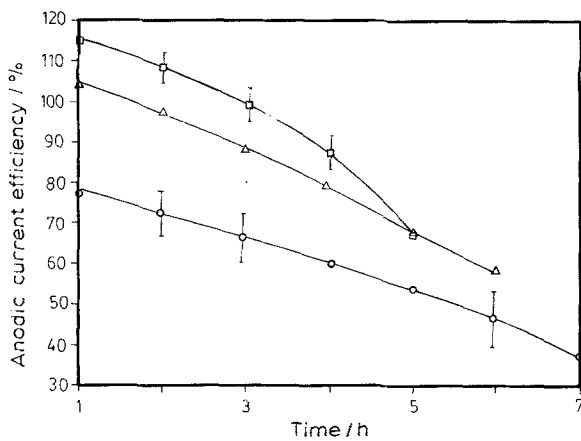

Fig. 5. Anodic current efficiency in different electrode layers of a bipolar reactor, flow rate $2 \text{ dm}^3 \text{ min}^{-1}$ current 4 A. Layer: (□) 6, (Δ) 4 and (O) 2.

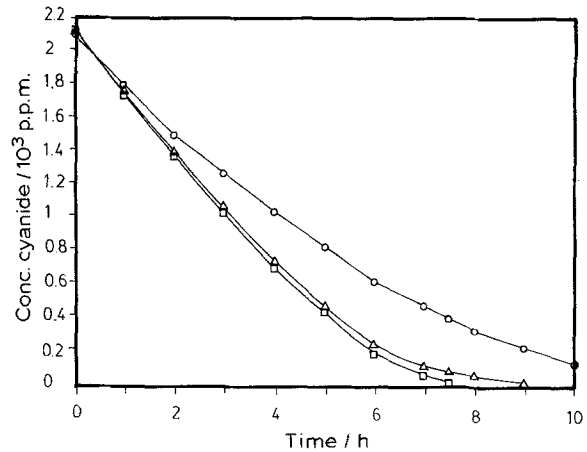

Fig. 8. Decomposition of cyanide in parallel reactors with different electrode layers, flow rate $2.0 \text{ dm}^3 \text{ min}^{-1}$, current 4 A. Layer: (□) 6, (Δ) 4 and (O) 2.

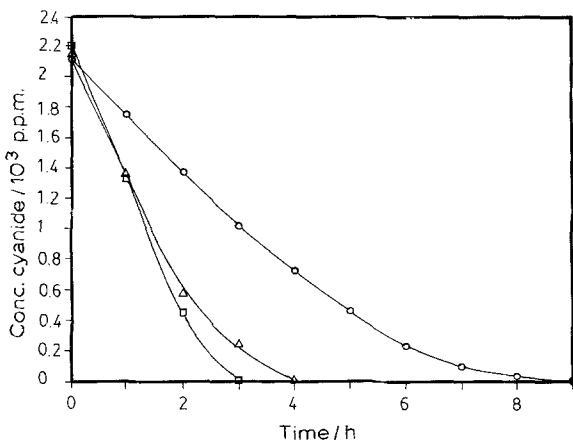

Fig. 6. Decomposition of cyanide with respect to electrolysis time in a 4-layer parallel reactor. Current, I/A: (□) 10, (Δ) 8 and (O) 4.

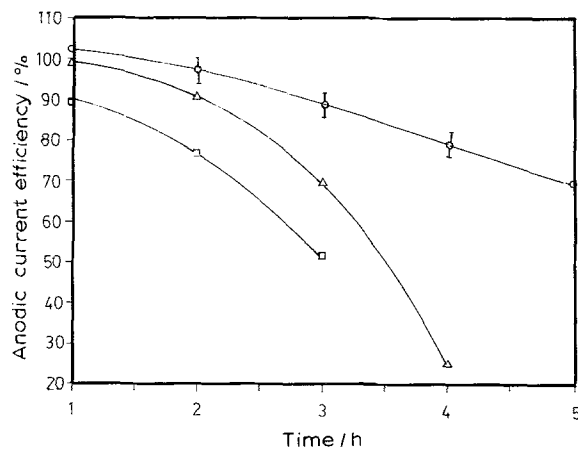

Fig. 7. Anodic current efficiency against electrolysis time in a 4-layer parallel reactor. Current, I/A: (□) 10, (Δ) 8 and (O) 4.

Table 1. Energy consumption of bipolar and parallel systems; applied current 8 A, time 3 h, 4 layers

System	Conversion/%	Energy consumption/ kWh kg^{-1}
Bipolar	99.9	42.45
Parallel	75.0	26.72

observed that reddish copper was deposited on the cathodes. In the parallel electrode, the deposition was quite uniform. However in the bipolar electrode, the amount of copper deposit on the cathode layer clearly decreased corresponding to its distance from the negative terminal. This means that the reaction does not occur uniformly in the bipolar electrode, which may also contribute to additional energy consumption.

Setting 99.7% conversion as a control goal and with electrolysis time as an operational variable energy consumptions were determined and the results are reported in Table 2. It is apparent that the difference in energy consumption becomes even more remarkable as the applied current is increased. The energy consumption for a parallel system increased from 20.1 kWh kg^{-1} to 28.7 kWh kg^{-1} when the current increases from 6 to 10 A, which reflects the additional charge transfer overpotential. By contrast, the bipolar system almost doubles its energy consumption. Although the bipolar system may show a moderate advantage regarding decomposition rate, the energy consumption factor definitely favours the parallel system.

A comparison can also be made based on an analogy of the equivalent electrical circuits. The bipolar

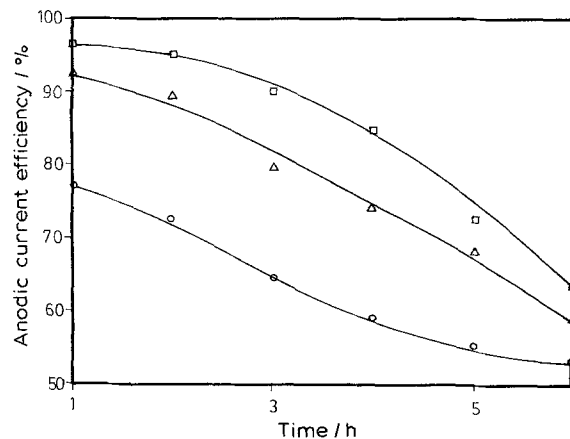

Fig. 9. Anodic current efficiency in different electrode layers of a parallel reactor, flow rate $2.0 \text{ dm}^3 \text{ min}^{-1}$, current 4 A. Layer: (□) 6, (Δ) 4 and (O) 2.

Table 2. Energy consumption of bipolar and parallel systems based on 99.7% conversion

System	Current/A	Energy consumption/ kWh kg ⁻¹
Bipolar	6	35.87
	8	42.45
	10	62.95
Parallel	6	20.14
	8	26.26
	10	28.71

system can be viewed as resistors in series, assuming 100% current efficiency and constant internal resistance. For N layers, the total energy consumption, P_t , is related to the time, t , and current, I , as follows:

$$P_t = NI^2Rt \quad (3)$$

The equivalent circuit for the parallel system is illustrated in Fig. 10. Each anode faces two cathodes, one on top and one below, which accounts for the two resistors in parallel on the right hand-side in each row. There is only one cathode, i.e. one resistor, in the first row. This is because the last anode at the bottom faces only one cathode. In this circuit, the total energy consumption P_t' is related to t and I as follows:

$$P_t' = \frac{6I^2Rt}{2N-1} \quad (4)$$

Therefore the ratio of energy consumption (RE) of these two systems would be

$$\begin{aligned} RE &= \frac{P_t}{P_t'} \\ &= \frac{2N^2 - N}{6} \end{aligned} \quad (5)$$

As N increases, the RE ratio also increases. The experimental results qualitatively agree with this prediction.

4. Conclusions

The electrochemical reactor, either in bipolar form or in parallel form, effectively decomposes cyanide from a copper cyanide solution. However the bipolar elec-

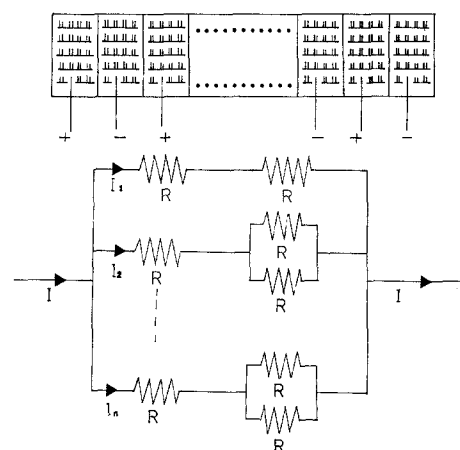

Fig. 10. Equivalent circuit of a parallel electrode with N layers.

trode was found to be more energy intensive and to exhibit nonuniform current density. Since the bipolar electrode and parallel electrode are structurally similar to resistors in series and parallel, respectively, their energy consumption ratio qualitatively agrees with the ratio of these two equivalent circuits. However, there is still a significant difference quantitatively, since the analogue circuit assumes 100% current efficiency and total uniform current distribution, which is far from reality.

Acknowledgement

This project was supported by the Chemical Division of the ITRI, Taiwan.

References

- [1] E. A. El-Ghaoui, R. E. Jansson and C. Moreland, *J. Appl. Electrochem.* **12** (1982) 69.
- [2] J. Hwang, Y. Wang and C. Wan, *ibid.* **17** (1987) 684.
- [3] S. Ho, Y. Wang and C. Wan, *J. Water Research* **24**(11) (1990) 1317.
- [4] H. Tamura, T. Arikado, H. Yoneyama and Y. Matsuda, *ibid.* **21** (1976) 1021.
- [5] F. Doodridge, C. J. King and A. Wright, *Electrochim. Acta.* **22** (1977) 347.
- [6] F. Hine, 'Electrode Processes and Electrochemical Engineering', Plenum Press, New York (1985).
- [7] J. Hwang, M.S. Thesis, Tsing-hua University (1989).
- [8] F. Ludzack, W. Moore and C. Ruchhoft, *Anal. Chem.* **26** (1954) 1784.
- [9] D. T. Chin and B. Eckert, *Plat. & Surf. Fin.* **63** (1976) 38.